

BIN VENT DUST COLLECTOR
BV Series





General Points

Comparing numerous air pollution control equipment, the dry fabric filter is by far the most efficient and reliable. Contrary to other filtering methods, variations in dust loading or air volume will not change the outlet conditions of a well-designed dry fabric collector. The pulse-jet system outperforms conventional dry fabric filter units since it allows the use of highly efficient felt filter fabrics.

The dust is collected on the outside of the filter bags. At regular intervals, a burst of compressed air is injecting through the PULSE collector parabolic velocity stacks to dislodge the agglomerated dust which falls out of the bottom.

Maximum filtering efficiency is attained by using top quality needle felt media of appropriate weight and construction. Full range of natural and synthetic felts are available to suit specific requirements. Glass, Polyester, Nylon, Nomex, etc.

Selection criteria for a Bin Vent dust collectors :

- 1- Type of Dust
- 2- Dust Concentrations
- 3- Process Conditions :
 - Temperature;
 - Humidity;
 - Corrosive agents;
 - Dew point.
- 4- Physical Constraints
- 5- Duct Static Pressure
- 6- Disposal Method



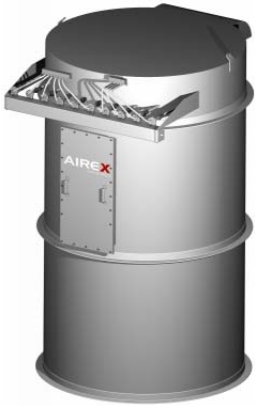

Theory of Operation

The dust laden air enters the collector from the bottom. Once inside, the dust accumulates on the surface of the bag filter creating a surface cake. Reverse blasts of air are introduced at specific intervals cleaning the bag surface and sending the debris towards the open bottom. This unit utilizes venturis to accelerate the blast into the bag creating a more efficient cleaning.

Maximum filtration can be obtained through selection of certain items that include bag types, can velocity, collector shape and arrangement.

Examples:

- Fibreglass;
- Polyester;
- Nylon;
- PTFE;
- Nomex;
- Etc.

Steel internal cage supports are used to keep the bag form. Quick clamp snap bands hold the bags in place. Bags and cages are accessed from below the tube sheet within the dirty side of the collector.

Advantages:

Pulse dust collectors feature the following advantages :

- Operation with constant pressure drop controlled with an electronic adjustable timer;
- Reduced maintenance due to few mechanical parts;
- Ability to operate with very high grain loading, up to 100 grains per cubic foot.





Technical Data Sheet – Bin Vent Dust Collector / BV SERIES

Model No.	9BV-6	9BV-8	16BV-8	21BV-8	25BV-8	37BV-8	37BV-10	45BV-10	57BV-10	69BV-10	78BV-10
No. of bags	9	9	16	21	25	37	37	45	57	69	78
Size of bags (ft)	6'-0"	8'-0"	8'-0"	8'-0"	8'-0"	8'-0"	10'-0"	10'-0"	10'-0"	10'-0"	10'-0"
Cloth area (ft ²)	68	90	160	210	250	370	463	563	713	863	975
No. of valves	3	3	4	5	5	7	7	7	9	9	9
A (in.) (diameter)	30"	30"	36"	42"	48"	54"	54"	60"	66"	72"	78"
B (ft.) (length)	6'-9"	8'-9"	8'-9"	8'-9"	8'-9"	8'-9"	10'-9"	10'-9"	10'-9"	10'-9"	10'-9"

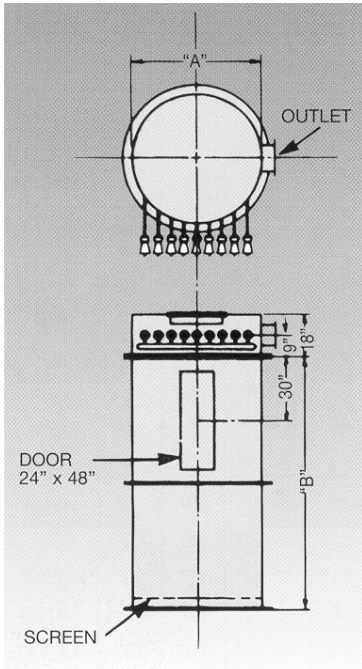

In order to have our product meet the highest technological standards, we reserve the right to modify its specifications without notice.

1-800-263-2303

Internet : www.airex-industries.com

E-Mail : airex@airex-industries.com

HEAD OFFICE

8030, Metropolitan Blvd East
 Montreal (QC) H1K 1A1
 T : (514) 351-2303
 F : (514) 352-5891

ONTARIO DIVISION

6800, Kitimat Road, unit 32
 Mississauga (ON) L5N 5M1
 T : (905) 821-3674
 F : (905) 821-4857

PLANT

3025, Bernier Road
 Drummondville (QC) J2C 6Y4
 T : (819) 477-3030
 F : (819) 477-3437